

INSTANTANEOUS OIL WATER HEATING DIRECT-VENT or CHIMNEY VENT

OM-148 INSTANTANEOUS DOMESTIC HOT WATER (DHW) HEATER:

- On demand means there is no costly storage of a large volume of hot water.
- Heats 240 gallons of water per hour @ 60°F temperature rise, 3.0 gpm @ 80°F ΔT.
- Never run out of hot water again!
- Save hundreds of dollars per year with fuel savings. 88% efficiency (90% OM-180).
- Stainless steel heat exchanger.
- Compact design allows for flexibility of installation location.
- 2 installation options, direct-vent or conventional chimney.

OM-180 COMPACT HYDRONIC & DHW HEATING SYSTEM:

- A water heater with a boiler attitude! Direct-vent or Chimney vent options.
- Radiant Floor, radiators, hydro-air, and more heating systems.
- 1-man installation, at only 81 lbs. Stainless steel cabinet.



Model	OM-148	OM-180
Oil Type	1K-Kerosene, #1 Stove Oil, or #2 Fuel Oil (indoor tank required for #2).	
Electrical Supply & Power Use	AC 120V, 60Hz	120W-Ignition, 98W-Operating
Efficiency	88% (AFUE)	90%, 83% (AFUE)
Heating Capacity	148,000 BTU/h	
System Application	Instantaneous On-Demand DHW Heater.	Instantaneous On-Demand DHW Heater, and Hydronic Heating Systems.
Oil Consumption	1.05 gal./h	
Maximum Temperature	155°F	176°F
Dimensions (WxHxD)	12-5/8" x 27-3/4" x 22-1/2"	
Weight	86 lbs (empty)	81 lbs (empty)
Required Accessories	Oil tank, In-line oil filter, and 3/8" copper oil line (purchase locally). Pressure & temperature safety relief (included with unit). Direct-vent kit, or 5" Chimney Adapter Kit (purchase extra from DigelAir).	
Oil Supply	Gravity feed from an external tank. An optional Fuel Lifter Pump is available.	

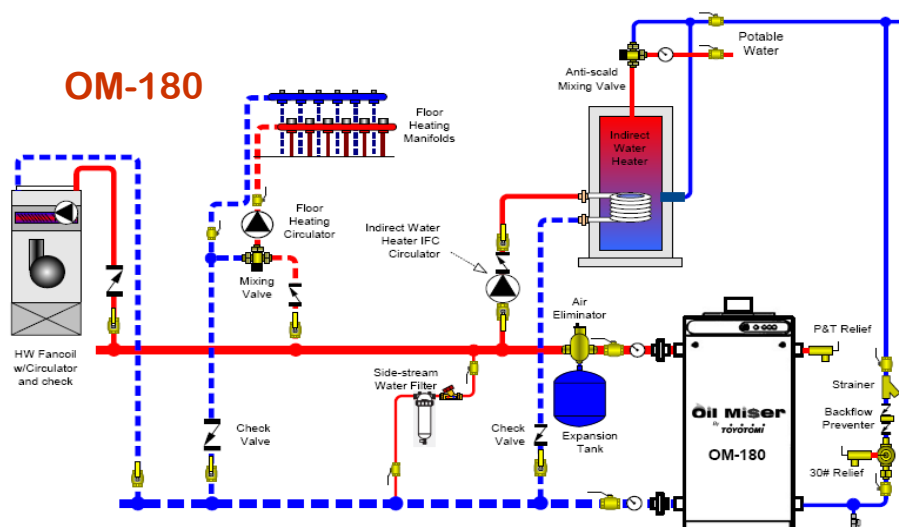

Contact us with your intended application for the OM-180 and we will help design the heating system for you!

Distributed By:

DigelAir
HVAC SUPPLY

1-21 Grenfell Cr.
Nepean, ON K2G0G3
(613)723-0359
www.digelair.com